



■ Features :

- Universal AC input / Full range
- Protections: Short circuit / Overload / Over voltage
- Cooling by free air convection
- LED indicator for power on
- 100% full load burn-in test
- All using 105°C long life electrolytic capacitors
- Withstand 300VAC surge input for 5 second
- High operating temperature up to 70°C
- Withstand 5G vibration test
- High efficiency, long life and high reliability
- 3 years warranty



SPECIFICATION

MODEL		RQ-50B				RQ-50C				RQ-50D			
OUTPUT	OUTPUT NUMBER	CH1	CH2	CH3	CH4	CH1	CH2	CH3	CH4	CH1	CH2	CH3	CH4
	DC VOLTAGE	5V	12V	-5V	-12V	5V	15V	-5V	-15V	5V	12V	24V	-12V
	RATED CURRENT	5A	1A	0.5A	0.5A	5A	1A	0.5A	0.5A	3A	0.9A	0.9A	0.5A
	CURRENT RANGE	0.5 ~ 6A	0.2 ~ 1.5A	0 ~ 1A	0 ~ 1A	0.5 ~ 6A	0.2 ~ 1.5A	0 ~ 1A	0 ~ 1A	0.5 ~ 6A	0.2 ~ 1.5A	0.1 ~ 1A	0 ~ 1A
	RATED POWER	45.5W				50W				53.4W			
	RIPPLE & NOISE (max.) Note.2	80mVp-p	120mVp-p	100mVp-p	80mVp-p	80mVp-p	120mVp-p	100mVp-p	80mVp-p	80mVp-p	120mVp-p	180mVp-p	80mVp-p
	VOLTAGE ADJ. RANGE	CH1: 4.75 ~ 5.5V				CH1: 4.75 ~ 5.5V				CH1: 4.75 ~ 5.5V			
	VOLTAGE TOLERANCE Note.3	±2.0%	±6.0%	±3.0%	±3.0%	±2.0%	±6.0%	±3.0%	±3.0%	±2.0%	±6.0%	+7,-5%	±3.0%
	LINE REGULATION Note.4	±0.5%	±1.5%	±0.5%	±0.5%	±0.5%	±1.5%	±0.5%	±0.5%	±0.5%	±1.5%	±2.0%	±0.5%
	LOAD REGULATION Note.5	±0.5%	±3.0%	±1.0%	±1.0%	±0.5%	±3.0%	±1.0%	±1.0%	±0.5%	±3.0%	±3.0%	±1.0%
SETUP, RISE TIME	500ms, 20ms/230VAC				1200ms, 30ms/115VAC at full load								
HOLD UP TIME (Typ.)	60ms/230VAC				10ms/115VAC at full load								
INPUT	VOLTAGE RANGE	88 ~ 264VAC		125 ~ 373VDC (Withstand 300VAC surge for 5sec. Without damage)									
	FREQUENCY RANGE	47 ~ 63Hz											
	EFFICIENCY (Typ.)	74%				75%				79%			
	AC CURRENT (Typ.)	1.3A/115VAC		0.8A/230VAC									
	INRUSH CURRENT (Typ.)	COLD START 36A/230VAC											
LEAKAGE CURRENT	<2mA / 240VAC												
PROTECTION	OVERLOAD	110 ~ 150% rated output power Protection type : Hiccup mode, recovers automatically after fault condition is removed											
	OVER VOLTAGE	CH1: 5.75 ~ 6.75V Protection type : Hiccup mode, recovers automatically after fault condition is removed											
ENVIRONMENT	WORKING TEMP.	-25 ~ +70°C (Refer to "Derating Curve")											
	WORKING HUMIDITY	20 ~ 90% RH non-condensing											
	STORAGE TEMP., HUMIDITY	-40 ~ +85°C, 10 ~ 95% RH											
	TEMP. COEFFICIENT	±0.03%/°C (0 ~ 50°C) on +5V output											
SAFETY & EMC (Note 6)	VIBRATION	10 ~ 500Hz, 5G 10min./1cycle, period for 60min. each along X, Y, Z axes											
	SAFETY STANDARDS	UL60950-1, TUV EN60950-1 approved											
	WITHSTAND VOLTAGE	I/P-O/P:3KVAC I/P-FG:2KVAC O/P-FG:0.5KVAC											
	ISOLATION RESISTANCE	I/P-O/P, I/P-FG, O/P-FG:100M Ohms / 500VDC / 25°C/ 70% RH											
	EMC EMISSION	Compliance to EN55032 (CISPR32) Class B, EN61000-3-2,-3											
OTHERS	EMC IMMUNITY	Compliance to EN61000-4-2,3,4,5,6,8,11, EN61000-6-2 (EN50082-2), heavy industry level, criteria A											
	MTBF	162.9Khrs min. MIL-HDBK-217F (25°C)											
	DIMENSION	99*97*36mm (L*W*H)											
NOTE	PACKING	0.41Kg; 45pcs/19.5Kg/0.9CUFT											
		<p>1. All parameters NOT specially mentioned are measured at 230VAC input, rated load and 25°C of ambient temperature.</p> <p>2. Ripple & noise are measured at 20MHz of bandwidth by using a 12" twisted pair-wire terminated with a 0.1uf & 47uf parallel capacitor.</p> <p>3. Tolerance : includes set up tolerance, line regulation and load regulation.</p> <p>4. Line regulation is measured from low line to high line at rated load.</p> <p>5. Load regulation is measured from 0% to 100% rated load.</p> <p>6. The power supply is considered a component which will be installed into a final equipment. All the EMC tests are been executed by mounting the unit on a 360mm*360mm metal plate with 1mm of thickness. The final equipment must be re-confirmed that it still meets EMC directives. For guidance on how to perform these EMC tests, please refer to "EMI testing of component power supplies." (as available on http://www.meanwell.com)</p>											

■ Mechanical Specification

Case No. 905B Unit:mm

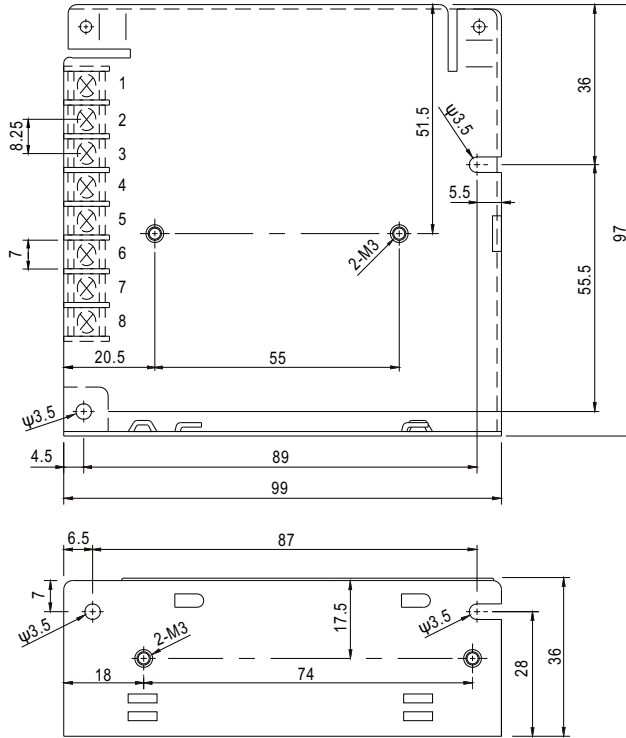

Terminal Pin No. Assignment

Pin No.	Assignment	Pin No.	Assignment
1	AC/L	5	DC OUTPUT V3
2	AC/N	6	DC OUTPUT +V2
3	FG \perp	7	DC OUTPUT COM
4	DC OUTPUT -V4	8	DC OUTPUT +V1

■ Block Diagram

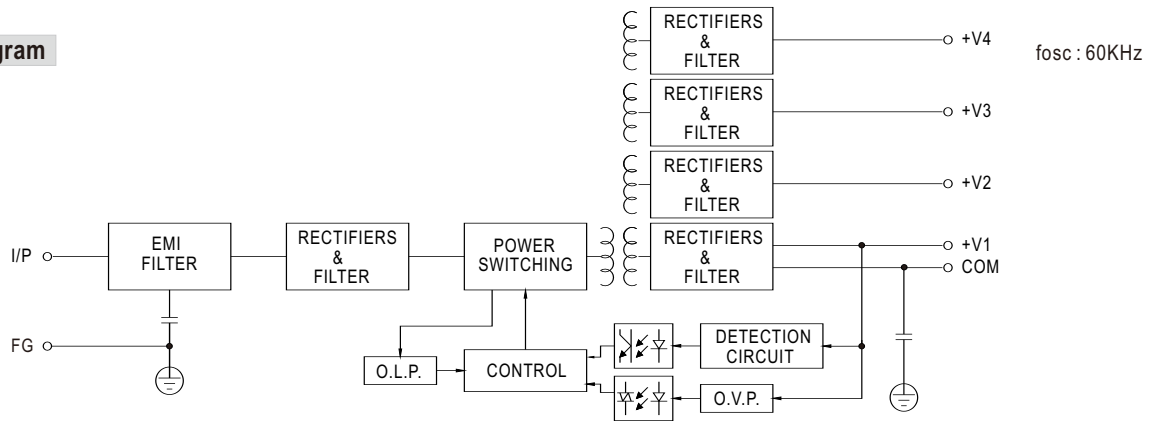

■ Derating Curve

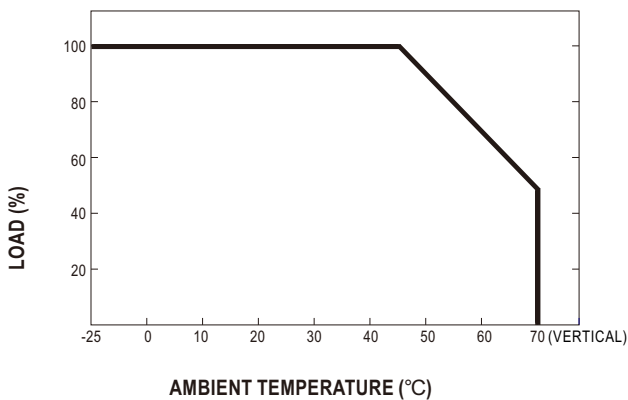

■ Output Derating VS Input Voltage

