

Frame: Thermoplastic, PBT (30%), UL94-V0  
 Impeller: Thermoplastic PBT (GF 15%), UL94-V0  
 Bearing System: Ball Bearing or Sleeve Bearing.  
 Lead Wire: UL 1007, AWG 26/270mm, Red(+), Black(-)  
 Protection: Locked rotor protected for minimum 72 hours

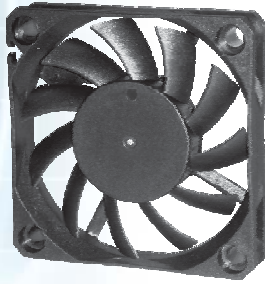

### Available Functions

1a. IR	1b. AS	1c. MS	2a. FG	2b. RD	2c. RDb	2d. LD	3. SG/PWM
	●		●	●	●		
4. OV	5a. TPWM	5b. RPWM	6. CL	7. CS	8a. VPWM	8b. IPWM	8c. PPWM

Part Number	Voltage (VDC)	Current (Amp.)	Power (Watts)	Speed (RPM)	Air Flow (Q) (CFM) (m <sup>3</sup> /min)	Pressure (P) (mmAq) (In H <sub>2</sub> O)	Noise (dBA)	Unit Weight (Q'TY/CTN)	
C6010H05BPLBx-11	05 (04~06)	0.273	1.37	4000	15.64	0.443	2.43	0.096	29.0g (480pcs)
C6010M05BPLBx-11		0.191	0.96	3600	13.63	0.386	1.93	0.076	
C6010L05BPLBx-11		0.136	0.68	3200	11.25	0.318	1.38	0.054	
C6010H12BPLBx-11	12 (07~14)	0.209	2.51	4600	17.54	0.497	3.08	0.121	29.0g (480pcs)
C6010M12BPLBx-11		0.152	1.83	4000	15.64	0.443	2.43	0.096	
C6010L12BPLBx-11		0.134	1.61	3600	13.63	0.386	1.93	0.076	
C6010H24BPLBx-11	24 (15~27)	0.110	2.64	4600	17.54	0.497	3.08	0.121	29.0g (480pcs)
C6010M24BPLBx-11		0.084	2.02	4000	15.64	0.443	2.43	0.096	
C6010L24BPLBx-11		0.060	1.44	3600	13.63	0.386	1.93	0.076	

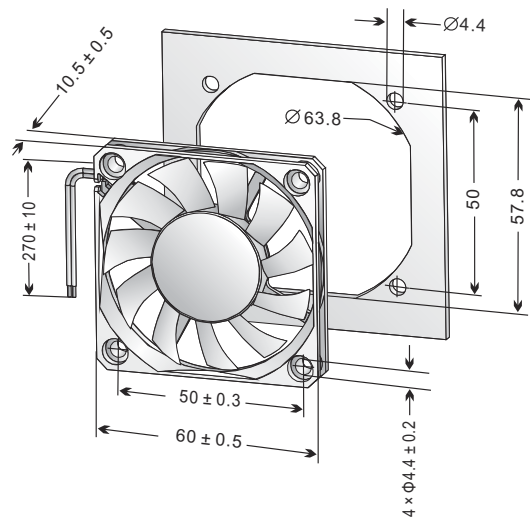
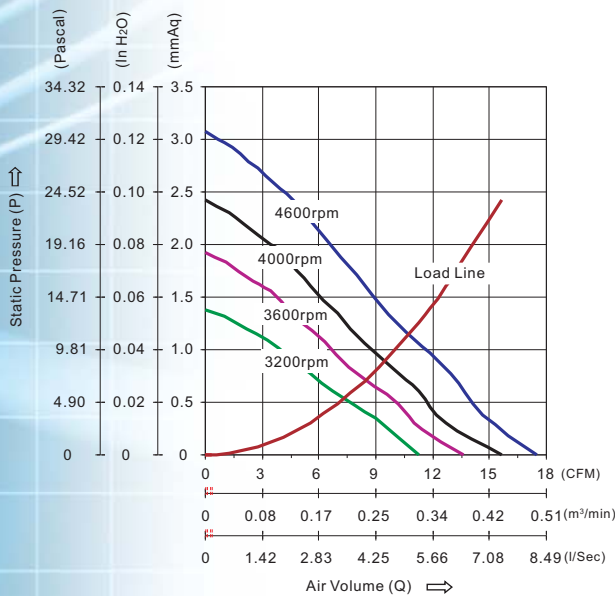

\* All **PELKO** fans listed here refer to double ball bearing types; Sleeve bearing types may consume about 10% more power for the same speed.  
 \* Noise Measurements are taken with background noise of 16.8 dBA.  
 \* Please see "Functions Legend" for explanation of each function.  
 \* Specifications are subject to change without notice.